

Maximum power control strategy of solar panel based on Artificial Neural Network using Quadratic Boost Converter

Fanessa Olivia¹, Muldi Yuhendri¹

¹Department of Electrical Engineering, Faculty of Engineering, Universitas Negeri Padang, Padang, Indonesia

Article Info

Article history:

Received May 1, 2025

Revised May 25, 2025

Accepted June 1, 2025

Keywords:

Renewable Energy

Solar Panel

MPPT

Quadratic Boost Converter

Artificial Neural Network

ABSTRACT

This research proposes and implements a Maximum Power Point Tracking (MPPT) control system on solar panels using a quadratic boost converter controlled by a backpropagation-based Artificial Neural Network (ANN) algorithm. The system is designed to maximize the output power of a 2x50 WP solar panel by reading current and voltage data, then calculating the power change (ΔP) which is used as JST training input to produce the optimal duty cycle value. This value is then used to adjust the PWM signal that controls the operation of the converter. The testing was conducted using real hardware connected to the Arduino Mega 2560, and programming was done through MATLAB Simulink. The JST training results show a very low Mean Squared Error (MSE) and high prediction accuracy with a regression coefficient (R) value approaching 1. The system has proven capable of reaching a maximum power point (MPP) of 52 watts in just 21 seconds with minimal power fluctuations. Thus, this JST-based MPPT control system demonstrates efficient, accurate, and responsive performance in optimizing the output power of solar panels.

Corresponding Author:

Fanessa Olivia

Department of Electrical Engineering, Faculty of Engineering, Universitas Negeri Padang

Kampus UNP Pusat, Jl. Prof. Hamka, Air Tawar, Padang 25131, Indonesia

Email: fanessaolivia37@gmail.com

1. INTRODUCTION

Energy has long been a component of the needs of the population in any country, including Indonesia. As time goes by, the continuously increasing population of Indonesia allows for a greater use of energy. The community's need for energy serves as a starting point for other aspects of human life, such as education, health, transportation, and the economy [1]. Currently, the total energy demand worldwide reaches around 10 Terawatts or 10,000 gigawatts per year, equivalent to 3×10^{20} Joules/year. The increasing energy demand is not in line with humanity's need to create a clean, healthy, and pollution-free environment. For that reason, solar energy becomes the solution. Solar energy, also known as solar power, is believed to be able to address the problem of energy needs throughout the day after various conventional energy sources have fluctuating quantities and less favorable effects on the environment [2].

The temperature and solar radiation affecting the surface of the solar panel determine the maximum electrical power that can be achieved [3]-[5]. The voltage and current characteristics, the output power of the solar panel vary with a certain level of radiation and temperature, and within that variation, there is a maximum value that can be obtained. When the solar panel receives changes in radiation temperature, there is a maximum output power from the solar panel influenced by different currents and voltages. One of the methods used to obtain the maximum output power value of solar panels is Maximum Power Point Tracking (MPPT), where its operation involves controlling the output voltage of the solar panels at the maximum power point. The voltage control of solar panels to achieve maximum power can use a DC-DC converter, such as a buck converter, boost converter, or other types of DC-DC converters. Each converter has different characteristics. In this study, an MPPT control system for solar panels using a boost converter is proposed.

The boost converter was chosen because it has the characteristic of an output voltage greater than its input voltage [4].

The maximum amount of solar panel voltage with a boost converter can be achieved by adjusting the pulse modulation of the semiconductor switch in the converter. This modulation pulse will turn the semiconductor on and off, allowing the converter output to be adjusted as desired. One method to control the on/off time of the semiconductor in a power converter is by using pulse width modulation (PWM) [3]. Several MPPT algorithm methods have been previously applied to the maximum power control system of solar panels, such as the Perturbation and Observation algorithm [5], Fuzzy Logic Control algorithm [6], Incremental Conductance [7], Curve Computation Method [8], Effectiveness of FPPT and Fuzzy-P&O [9], Anti-Drift MPPT algorithm [10], MPPT-Based SEPIC Converter Control [11], Backstepping method [12], . Each MPPT algorithm has its advantages and disadvantages. A good MPPT algorithm is one that does not take a long time to find the maximum power point and has low power ripple at its maximum point.

The Artificial Neural Network (ANN) algorithm is used to adjust the duty cycle of the switch converter in the MPPT control system. The implementation of this ANN uses the backpropagation method because it can provide various duty cycle changes. In this study, the JST-based MPPT control system will be applied to two solar panels with a capacity of 50 Watt Peak (WP) using the Arduino Mega 2560 as the control device.

2. METHOD

This research was conducted by applying an MPPT control system for a 2x50 WP solar panel. The MPPT system is designed using a quadratic boost converter to control the output voltage of the solar panel. Adjusting the PWM pulse width is done to control the output voltage on the boost converter used. The MPPT control system designed in this study is implemented with an Arduino Mega 2560 using Simulink MATLAB for its programming.

Figure 1 is a schematic of the MPPT control system on a photovoltaic with a dc-dc converter, using a JST backpropagation-based MPPT algorithm. From this research, the data collected includes the current and voltage output of the solar panel to obtain power and power changes, which will be used as input data for the Artificial Neural Network algorithm. Meanwhile, the output data is the desired change in duty cycle. Then the data will be trained using the Artificial Neural Network algorithm in the Matlab application to determine the duty cycle value of the PWM signal that will be sent to the DC-DC converter to determine the voltage value, thus producing the maximum power point [3],

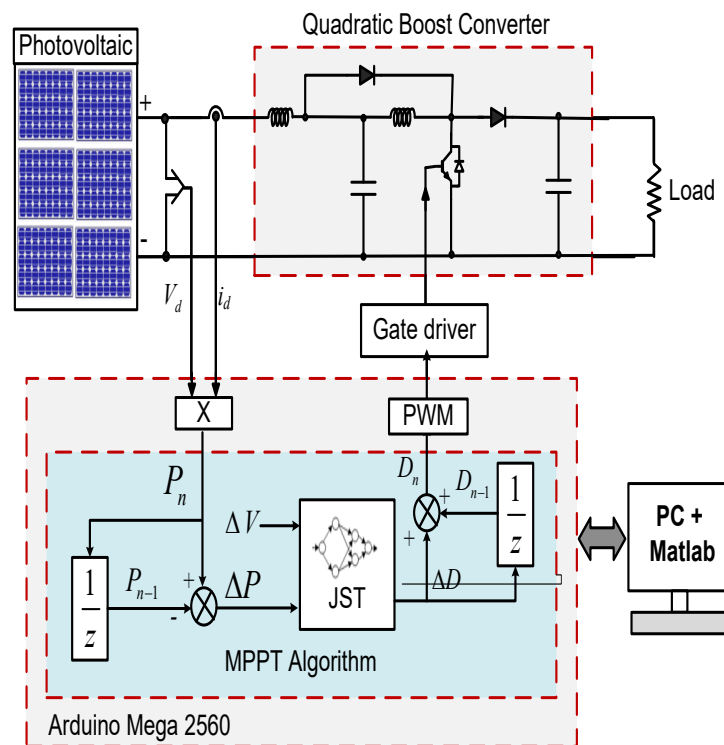

Figure 1. Backpropagation Neural Network -based MPPT Algorithm

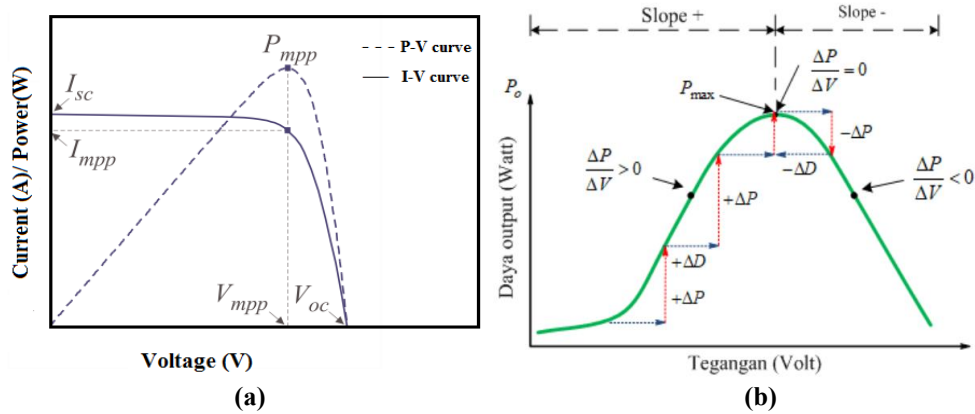

Figure 2. MPPT System (a) Maximum Power Point (b) perturb and observe algorithm (P&O)

The MPPT algorithm based on Neural Networks is an enhancement of the P&O algorithm to address the weakness of the P&O algorithm, which is having a constant duty cycle value. Because if a large value of ΔD is given, it will cause a large power ripple at the maximum power point. On the other hand, if the value of ΔD is small, it will slow down the algorithm in reaching the maximum power point. Therefore, in this study, an MPPT algorithm based on Artificial Neural Networks is used to obtain varying ΔD values that can accelerate the algorithm in reaching the maximum power point and reduce power ripple [3]. Figure 2(b) above shows the working principle of the P&O algorithm. The data needed to determine the duty cycle value in P&O is the change in power per change in voltage ($\Delta P/\Delta V$) as follows:

$$D = D_{n-1} \quad \text{if} \quad \frac{\Delta P}{\Delta v} = 0 \quad (1)$$

$$D = D_{n-1} + \Delta D \quad \text{if} \quad \frac{\Delta P}{\Delta v} > 0 \quad (2)$$

$$D = D_{n-1} - \Delta D \quad \text{if} \quad \frac{\Delta P}{\Delta v} < 0 \quad (3)$$

From the formula above, it can be determined that D_{n-1} is the previous duty cycle value, and then the value ΔD , which is the change in duty cycle, is obtained. The P&O-based MPPT algorithm usually obtains the value by decreasing or increasing the duty cycle by a constant value [13].

Artificial Neural Network (ANN)

Artificial Neural Networks are representations of the human body's nerves that simulate human nerve functions. Artificial Neural Networks (ANNs) have several characteristics similar to human neurons, including multiple neurons and connections between neurons known as weights [3].

The principle of operation of artificial networks is that information or input is sent to neurons through the arrival of certain weights. This input will be processed by the propagation function, which will calculate all the incoming weights. The sum is compared with the threshold value determined by the neuron activation function. If the input value is less than the threshold value, the neuron will be activated by the activation function. If the neuron in question is active, it will send its output to all neurons connected to it through its output weights, and it will do so in the same process.

Backpropagation Neural Network Algorithm

Neural networks that use supervised learning methods are known as backpropagation. Two types of outputs that can be provided by the algorithm for neural network learning to achieve the desired results are forward propagation and backward propagation [14]. To obtain a JST Backpropagation model that can produce the desired output, the JST will first be trained by preparing the input data and target output data. As mentioned earlier, the input data is the power change value (ΔP) and the output data is the duty cycle change (ΔD).

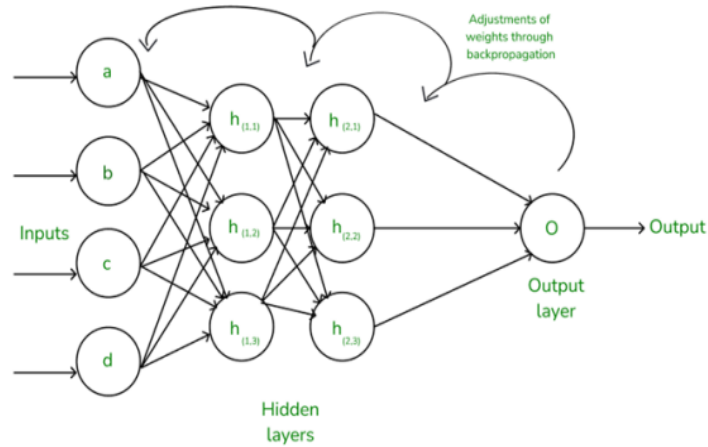

Figure 3. JST Backpropagation Architecture

The JST Backpropagation-based MPPT algorithm is used in this research to obtain varying (ΔD) values, to accelerate the algorithm in reaching the maximum power point and to reduce power ripple at the maximum power point. The change in duty cycle (ΔD) will determine the duty cycle for PWM(D_n), which is calculated using the equation:

$$D_n = \Delta D + D_{n-1} \tag{4}$$

Where D_{n-1} is the previous duty cycle value.

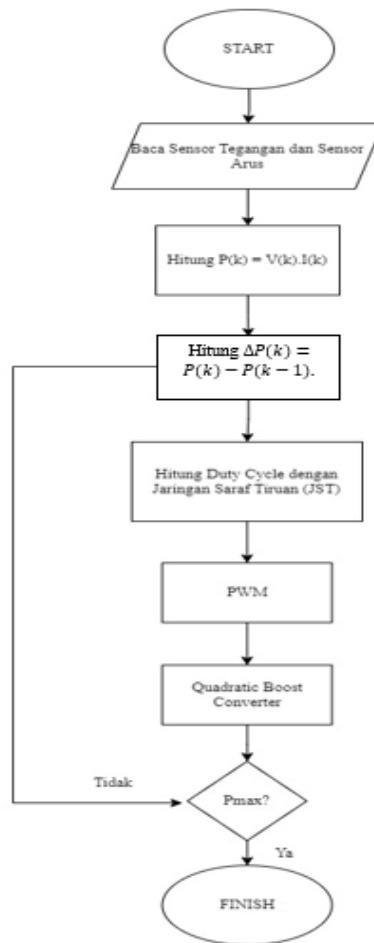

Figure 4. Overall System Flowchart

Figure 4 above is the flowchart of the working system of the Artificial Neural Network algorithm used for the MPPT control system in this research. This system works by reading the current and voltage from the solar panel $P(k) = V(k) \cdot I(k)$. Next, the microcontroller calculates the power change $\Delta P(k) = P(k) - P(k-1)$, which is used as input for JST training, and the output is in the form of the duty cycle value. This duty cycle indicates the PWM that controls the operation of the quadratic boost converter to optimize the output voltage of the solar panel.

3. RESULTS AND DISCUSSION

In this study, it is implemented on a 2x50 WP solar panel installed on the laboratory roof as shown in Figure 5. The solar panel terminals on the laboratory roof are connected to the panels inside the laboratory. Then the panels in the lab are arranged in parallel to conduct equipment testing.



Figure 5. solar panel (a) The solar panels are installed on the laboratory roof. (b) solar panel in the laboratory

When the solar panels receive changes in temperature and light intensity from sunlight, it will be reflected in the changes in current and voltage on the panels in the laboratory. The panels that have been assembled in parallel are then connected to a device to test the validation of the quadratic boost converter as well as the current and voltage on the device.



Figure 6. Hardware Quadratic Boost Converter with Measuring Instrument

After validating the quadratic boost converter, the current sensor and voltage sensor were successfully implemented, then connected to a computer to run the program and load was applied.



Figure 6. Overall Hardware System

Figure 7 is the complete hardware circuit that will be tested using the MPPT system program with the Neural Network algorithm on Simulink Matlab. The testing was conducted at 14:20 WIB under slightly cloudy and sunny weather conditions. As a result, there were several tests conducted that affected the temperature of the solar panels and the variation in light intensity. Here are the results of the MPPT control system tests using the Artificial Neural Network algorithm.

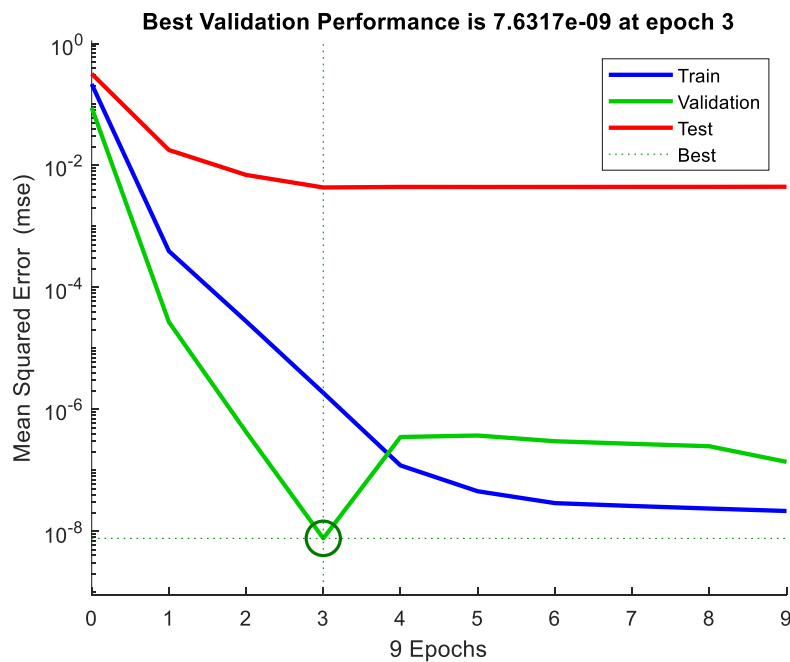

Figure 8. The results of the artificial neural network training (Mean Squared Error (MSE))

Figure 8 shows the training data results of the Artificial Neural Network from the input and output MSE data, with the training data showing a result of $7.6317e-09$ at epoch 3. This result shows that the error rate produced is very small and the accuracy level of the ANN is good enough to be used, and it is ready to be implemented in the Simulink MATLAB program.

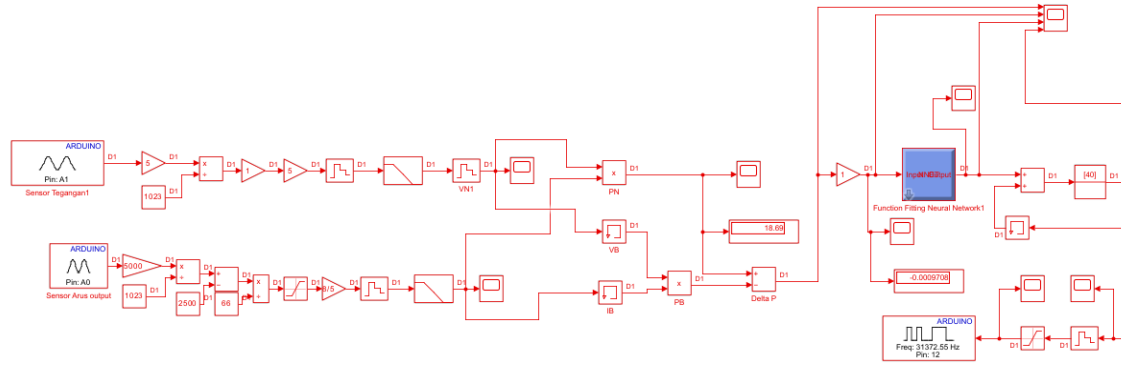

Figure 9. MPPT system program with JST algorithm in Simulink Matlab

The results of the MPPT control system testing with the Artificial Neural Network algorithm are shown in Figure 10, where the data is displayed as current versus voltage after testing the system with the Artificial Neural Network algorithm.

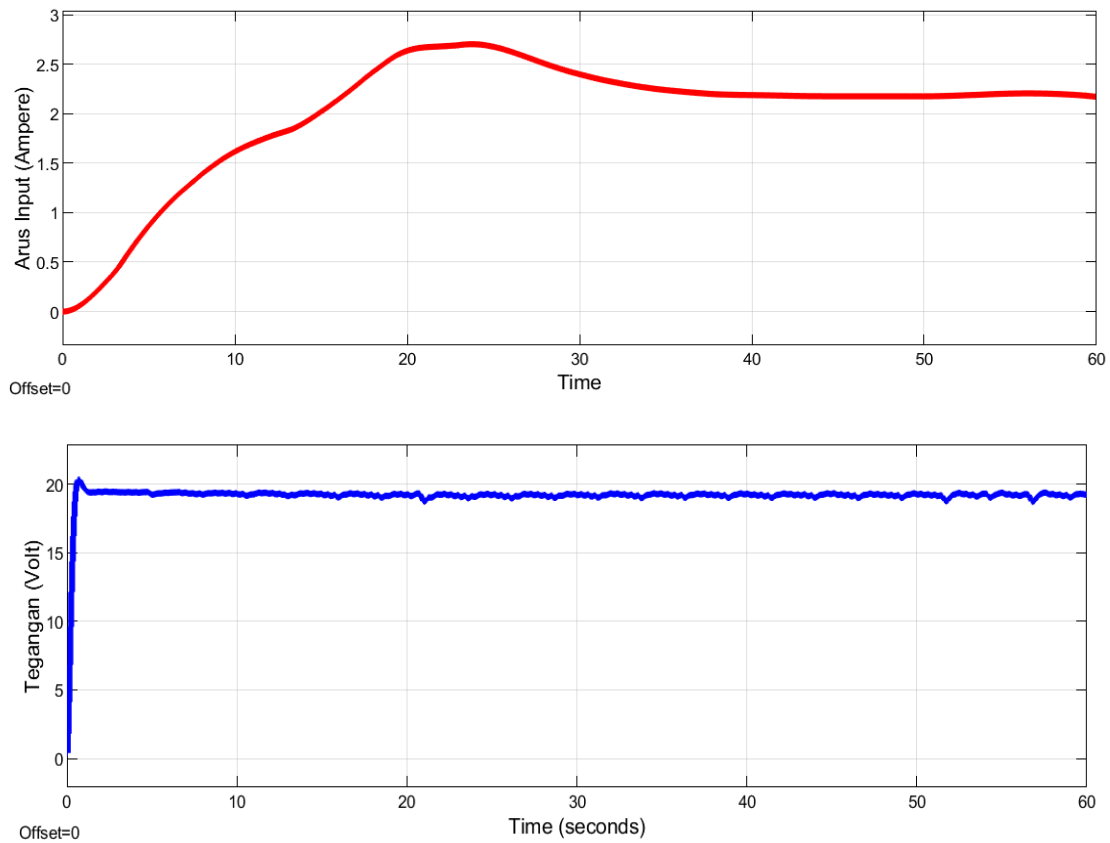

Figure 10. Current versus voltage of the solar panel after installing the quadratic boost converter

Figure 11 shows the maximum power value after the installation of the MPPT control system using the Artificial Neural Network algorithm. from the results obtained, the maximum power point can be reached at 52 watts in 21 seconds. This means that the Artificial Neural Network algorithm is able to quickly reach the maximum power point of the solar panel, so the maximum power generated by the solar panel can be used on the load.

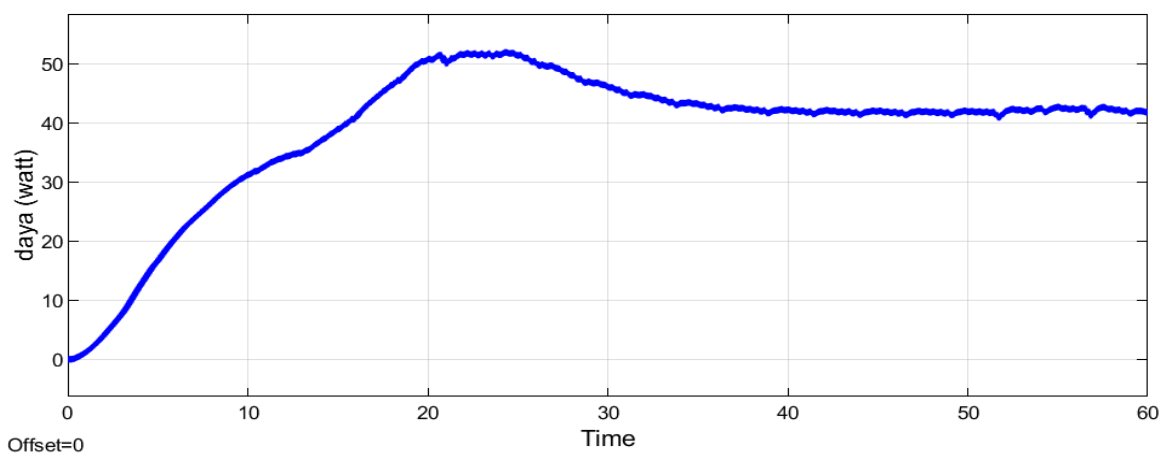

Figure 11. Maximum power of the MPPT system with the Neural Network algorithm

4. CONCLUSION

The goal of the MPPT control system is to adjust the output power of the solar panel to reach its maximum at every change in temperature and solar radiation. The MPPT algorithm used determines the performance of the MPPT control system. In this study, the MPPT algorithm based on Artificial Neural Networks is implemented with Arduino Mega 2560 to control the power of 2x50 WP solar panels. The use of the ANN algorithm is to accelerate the MPPT algorithm to reach the maximum power point and minimize power ripple at the maximum point of the solar panel. The test results show that the MPPT control system created with the Artificial Neural Network algorithm has worked well, where the algorithm successfully reached maximum power in 21 seconds with smooth power ripples at the maximum point.

REFERENCES

- [1] R. R. Al Hakim, "Model Energi Indonesia, Tinjauan Potensi Energy Terbarukan Untuk Ketahanan Energi Di Indonesia: Literatur Review," *ANDASIH J. Pengabd. Kpd. Masy.*, vol. 1, no. 1, pp. 1–11, 2020, [Online]. Available: <https://jurnal.umitra.ac.id/index.php/ANDASIH/article/view/374/253>
- [2] I. Kurniawan, M. Yuhendri, A. Hendra, and R. Hidayat, "Implementation of Maximum power control of Solar Panels using Modified Perturb and Observe Algorithm based on Adaptive Neuro Fuzzy Inference System," *Journal of Industrial Automation and Electrical Engineering.*, vol. 01, no. 01, pp. 200–208, 2024.
- [3] I. F. Sanul and M. Yuhendri, "Sistem Kendali MPPT Panel Surya Dengan Menggunakan Algoritma Jaringan Saraf Tiruan," *JTEIN J. Tek. Elektro Indones.*, vol. 4, no. 1, pp. 345–352, 2023, [Online]. Available: <http://jtein.pj.unp.ac.id/index.php/JTEIN/article/view/391%0Ahttp://jtein.pj.unp.ac.id/index.php/JTEIN/article/download/391/181>
- [4] A. Lindo and M. Yuhendri, "Sistem Kendali Daya Maksimum Panel Surya Berbasis Fuzzy Logic Controller," *JTEIN J. Tek. Elektro Indones.*, vol. 3, no. 1, pp. 102–110, 2022, doi: 10.24036/jtein.v3i1.207.
- [5] A. Fauzi, M. Facta, and S. Sudjadi, "Perencanaan Maximum Power Point Tracking (Mppt) Dengan Metode Perturb and Observe Pada Panel Surya," *Transient*, vol. 7, no. 4, p. 918, 2019, doi: 10.14710/transient.7.4.918-924.
- [6] T. M. Asyadi, I. D. Sara, and S. Suriadi, "Metode Maximum Power Point Tracking (MPPT) dan Boost Converter Menggunakan Fuzzy Logic Controller (FLC) pada Modul Surya," *J. Rekayasa Elektr.*, vol. 17, no. 1, pp. 1–6, 2021, doi: 10.17529/jre.v17i1.17863.
- [7] M. Yuhendri and G. S. Putra, "Implementasi Sistem Kendali MPPT Panel Surya Berbasis Algoritma Incremental Conductance," *JTEIN J. Tek. Elektro Indones.*, vol. 1, no. 2, pp. 218–223, 2020, doi: 10.24036/jtein.v1i2.72.
- [8] A. Ostadrahimi and Y. Mahmoud, "Curve Computation MPPT Method Based on Simple Modeling of the Photovoltaic Modules," *2020 International Conference on Smart Grids and Energy Systems (SGES)*, Perth, Australia, 2020, pp. 819–825, doi: 10.1109/SGES51519.2020.00151.
- [9] M. R. Hans, M. B. Gaikwad, M. K. Nigam and B. Patel, "Comparative Analysis of The Traditional Perturb and Observe with Studied FPPT Method and Fuzzy Logic Control Strategy Based P and O for the MPPT of a Photovoltaic System," *2021 IEEE Mysore Sub Section International Conference (MysuruCon)*, Hassan, India, 2021, pp. 372–377, doi: 10.1109/MysuruCon52639.2021.9641555.
- [10] X. Zhang, J. Song and Z. Chen, "Self-Optimized Drift-Avoidance MPPT Algorithm for Photovoltaic Systems," *2022 IEEE 4th International Conference on Civil Aviation Safety and Information Technology (ICCASIT)*, Dali, China, 2022, pp. 739–743, doi: 10.1109/ICCASIT55263.2022.9986947.
- [11] R. D. Dongare and B. N. Chaudhari, "Design of a Photovoltaic System using MPPT based SEPIC Converter control," *2021 2nd Global Conference for Advancement in Technology (GCAT)*, Bangalore, India, 2021, pp. 1–4, doi: 10.1109/GCAT52182.2021.9587673.
- [12] J. Wang, C. Wang, L. Dai, L. Wang, X. Wu and J. Zhou, "Research on MPPT of photovoltaic power generation based on Backstepping method," *2021 IEEE 16th Conference on Industrial Electronics and Applications (ICIEA)*, Chengdu, China, 2021, pp. 594–598, doi: 10.1109/ICIEA51954.2021.9516439.
- [13] H. Masrepol and M. Yuhendri, "Implementasi MPPT Panel Surya Berbasis Algoritma Perturbasi & Observasi (PO)

-
- Menggunakan Arduino,” *JTEIN J. Tek. Elektro Indones.*, vol. 2, no. 2, pp. 162–167, 2021, doi: 10.24036/jtein.v2i2.155.
- [14] A. P. Windarto, “Implementasi JST Dalam Menentukan Kelayakan Nasabah Pinjaman KUR Pada Bank Mandiri Mikro Serbelawan Dengan Metode Backpropogation,” *J-SAKTI (Jurnal Sains Komput. dan Inform.*, vol. 1, no. 1, p. 12, 2017, doi: 10.30645/j-sakti.v1i1.25.